

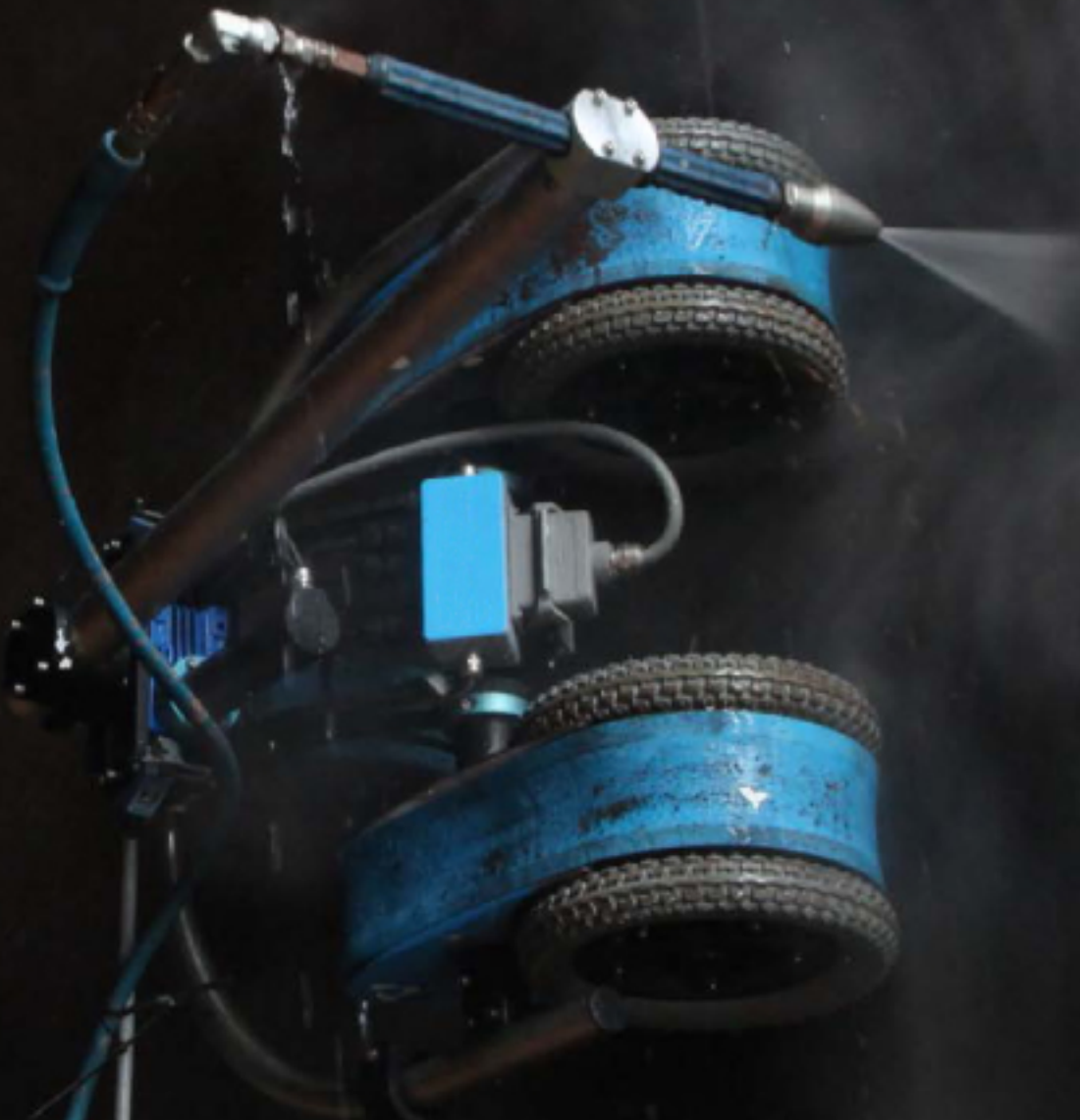

REVOLUTIONIZING CLEANING ROBOTS



Wuxi Hongyuan Pump Manufacturing Co.,Ltd



Introducing Robots for the future

Wuxi Hongyuan Pump Manufacturing Co.,Ltd was founded in 1994, It is an integrated High-Tech enterprise that gathered reasearch developepment and production,sale and service of high pressure cleaning equippmnt.

After continuous research, development and field-testing, the Hongyuan now introduces the M3 robot.

All of our systems are designed to meet the challenges of steel surface preparation.

Our robots enable shipyards, offshore and petrochemical industry to clean or blast steel surfaces, faster, safer, environmentally friendly and more cost-effective than possible with grit or manual UHP blasting while allowing other trades to simultaneously perform other maintenance procedures.

Our products offer significant advantages over the traditional methods to remove marine growth, industrial coatings and corrosion.

- The ability to work simultaneously in close proximity to other trades or maintenance processes
- Reduced manpower requirements
- No clean up costs
- Eliminates access requirements (staging, cranes, platforms, etc.)
- Safe, Clean and Efficient operation
- Full Service package

Index

4 - 5 M3 Washing applications

6 - 7 M3 Hydro Blasting & M3 Ultra High

8 - 9 Specials

10 -11 Technical specifications

M3 High Pressure Washing

Fast washing application

The M3 washing robot is designed for all vertical steel cleaning applications. It is remotely controlled for operator safety, comfort, and productivity.

The light weight construction and quick (dis)connect systems reduce the build up time to approximately 10 minutes. A rotating high pressure water nozzle (200 - 3000 bar) which is mounted on the reciprocating boom ensures a clean and effective result.

The machine adheres to the wall by a magnetic drive assembly and can move independently. There is no need for crane assistance or 'cherry pickers'.

Advantages compared to conventional cleaning methods

- Fast and efficient removal of dirt and or marine growth;
- Increased productivity, reduced maintenance costs;
- One man operation;
- Cleans horizontal, overhead and vertical surfaces (2 meter wide cleaning pattern);
- Ergonomic design and user-friendly, wireless remote.

Possibilities

- Petrochemical Industry (storage tanks);
- Offshore industry (offshore platforms);
- On shore industry (windmills);
- Maritime sector (ship yards).



Wireless remote controller

NEW!

Water driven robot

- Works in ATEX zone 1 & 2
- Robot can operate under water
- Driven by water hydraulic motors

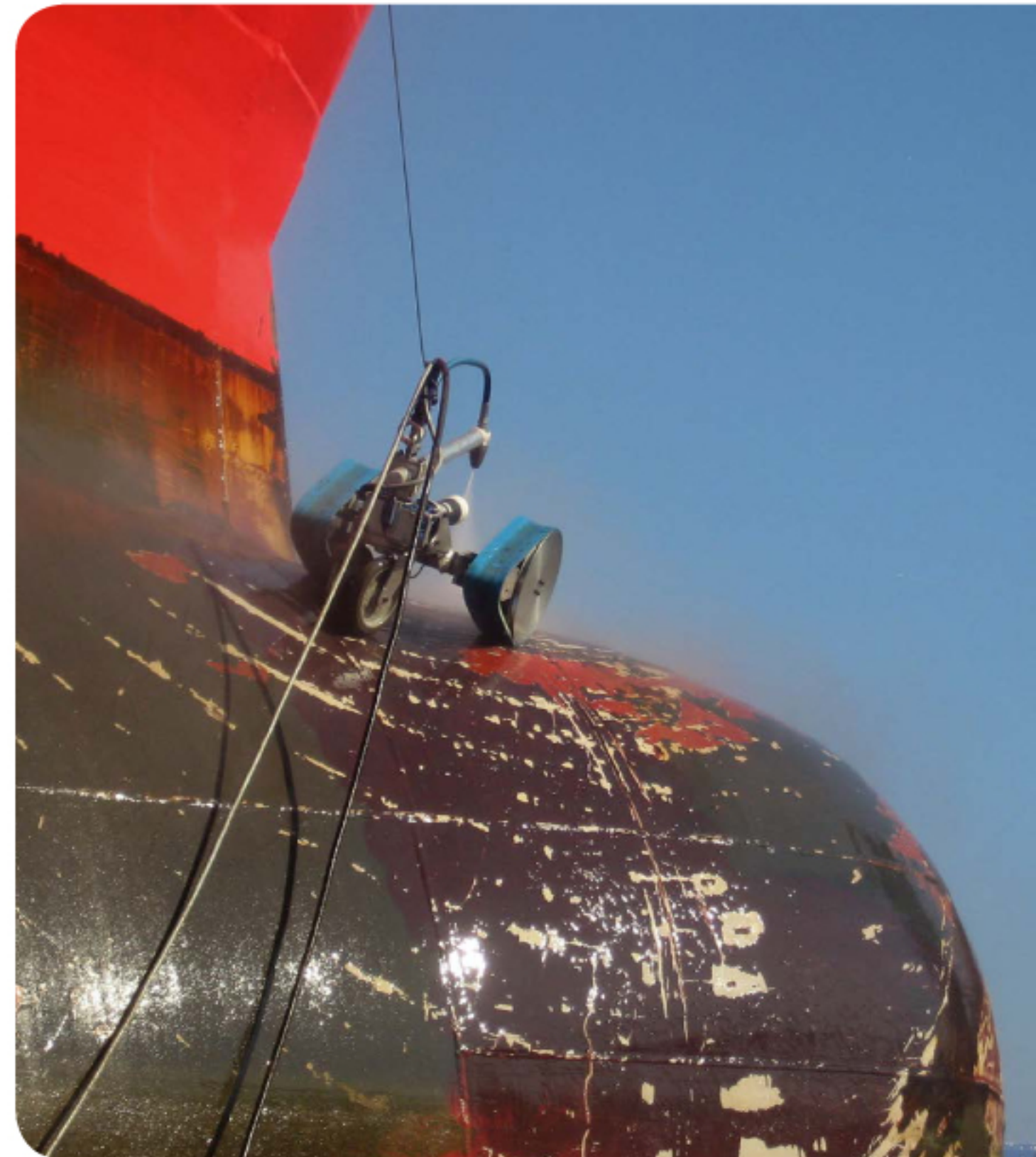

M3 Hydroblasting

Washing Application

The M3 Hydroblasting robot is designed to carry out any open hydro blast application on vertical or overhead steel surfaces. On the reciprocating boom any type of ultra high blasting nozzles can be mounted.

The machine adheres to the wall by a magnetic drive assembly and can move independently. There is no need for crane assistance or 'cherry pickers'. The wireless remote control endures operators safety en continuous operation.

We also offer a 20 cm wide electric driven rotor head equipped with 8 sapphire nozzle. The 20 cm wide blasting pattern combined with a 1,6 meter stroke of the reciprocating boom ensure high efficiency.

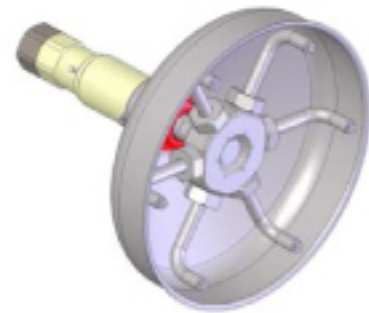

The M3 Hydroblasting robot can be delivered in 4 versions

- Electric driven 24 volt;
- Electric driven 24 volt ATEX zone 2 version;
- Air driven 6 bar ATEX zone 2 version;
- Water drive (water hydro motor) ATEX zone 1.

Advantages compared to conventional cleaning methods

- Fast and efficient removal of dirt and or marine growth;
- Increased productivity, reduced maintenance costs;
- One man operation;
- Cleans horizontal, overhead and vertical surfaces (1.6 meter wide cleaning pattern);
- Ergonomic design and user-friendly, wireless remote.

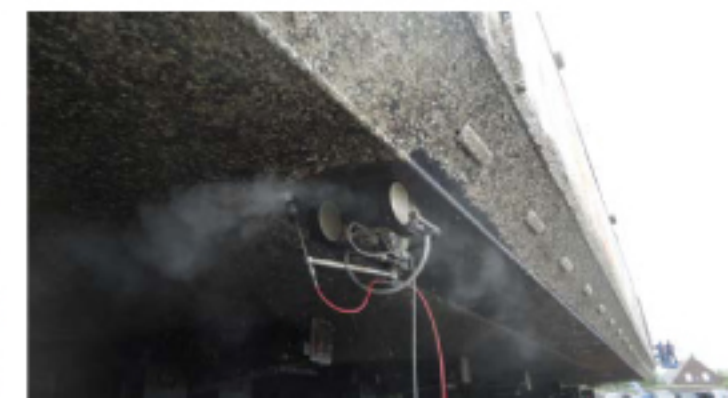
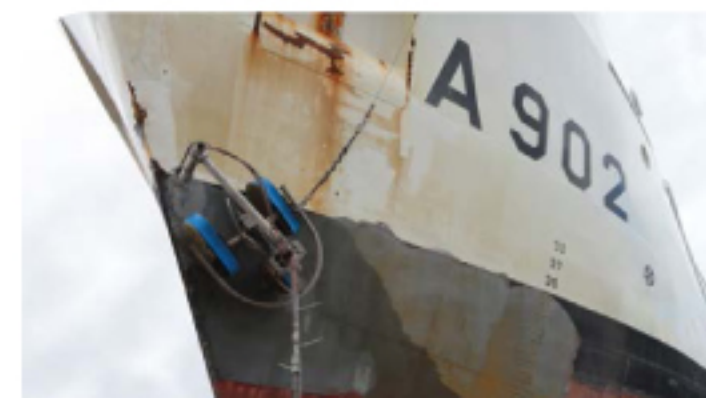

M3 Vacuum

Fast & environmental exculpatory



The M3 Vacuum is designed for all vertical steel coating removal or cleaning applications. The vacuum head mounted on the robot has a blast pattern of 40 cm wide, a self rotating high pressure water rotor head equipped with 18 nozzles (200 - 2500 bar) ensures a clean and effective result.

The machine adheres to the wall by a magnetic drive assembly and vacuum. In case the vacuum fails the robot will remain in position. It is remotely controlled for operator safety, comfort, and productivity. There is no need for crane assistance or 'cherry pickers'.

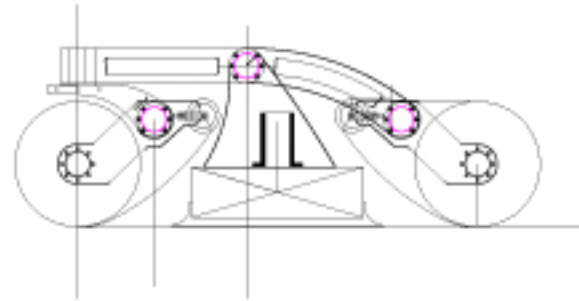

Advantages compared to conventional cleaning methods

- Fast and efficient removal of coatings, rust and mill scale;
- Dust free closed circuit operation, no flash rust;
- Increased productivity, reduced maintenance cost;
- One man operation;
- Cleans both horizontal and vertical surfaces (40cm wide blast pattern);
- Ergonomic design and user-friendly, wireless remote.

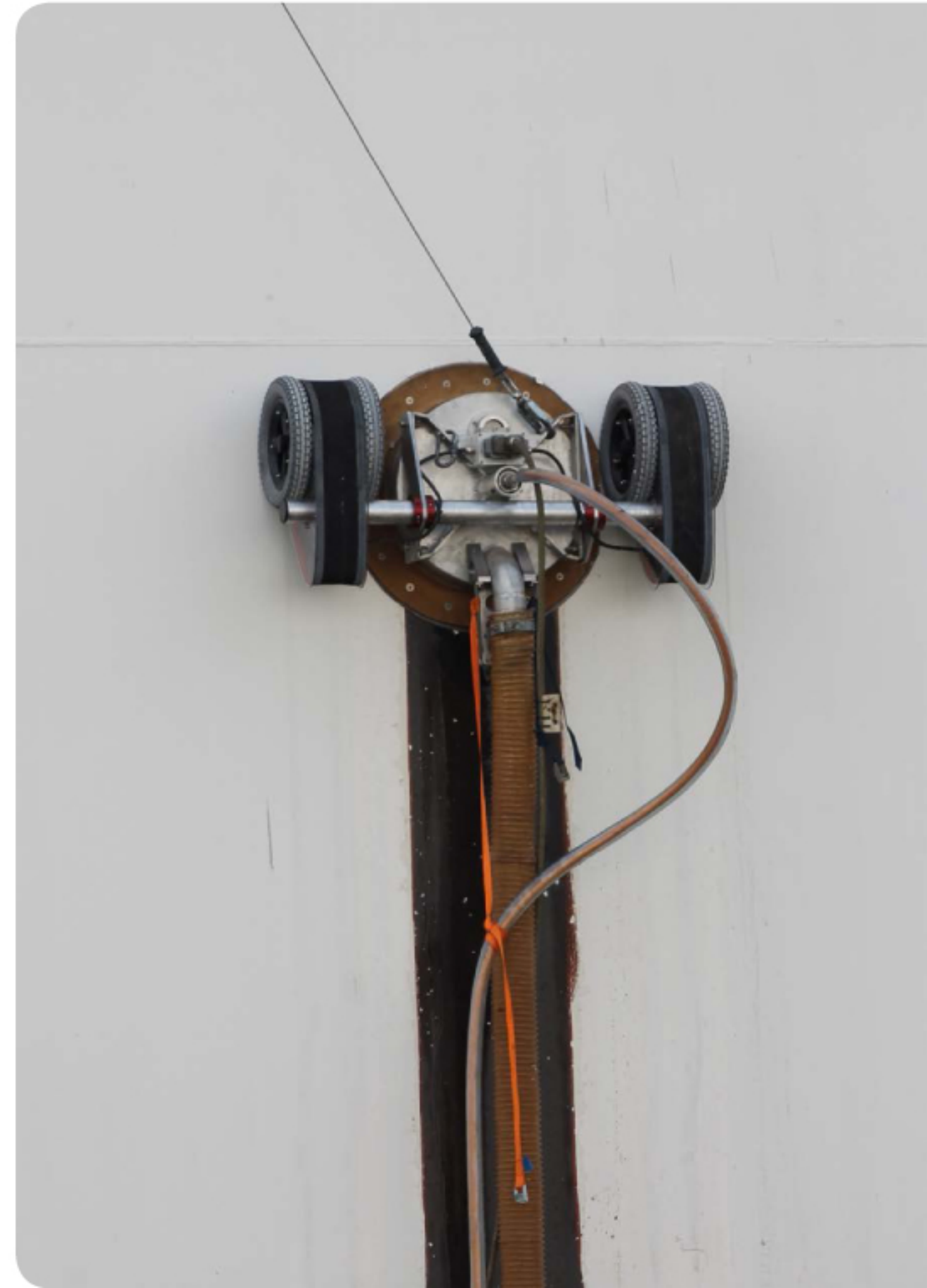
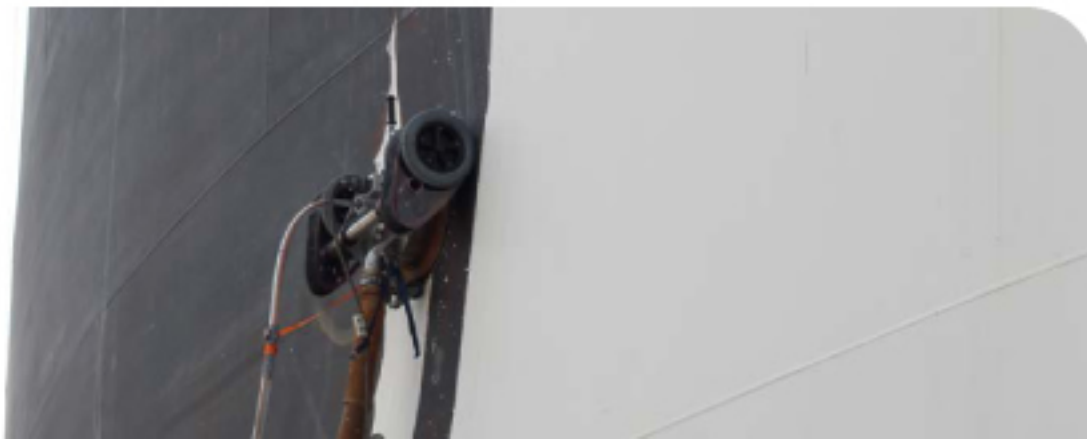

Pipecleaner

360 degrees performance

The M3 pipe cleaner is specifically designed to external clean or blast large pipes with diameters ranging from **600 mm** until **1500 mm**.

The magnetic drive unit does carry a rotating ring segment which turns 180 degrees. On either end of the ring two blast nozzles are mounted to cover a full 360 degree cleaning path.

Cleaning, hydro blasting or grit blasting can be carried out. Via a wireless control unit the M3 pipe cleaner can automatically move up and down the pipe. Even underwater operation is one of the possibilities of this unique design. Underwater cameras and level sensor can be mounted on the M3 pipe cleaner to carry out cleaning operation till 25 meter depth.

The rotating ring segment and main frame can be replaced with a Internal pipe cleaning device achieving cleaning operations of large pipes with internal diameters up to 3 meters.

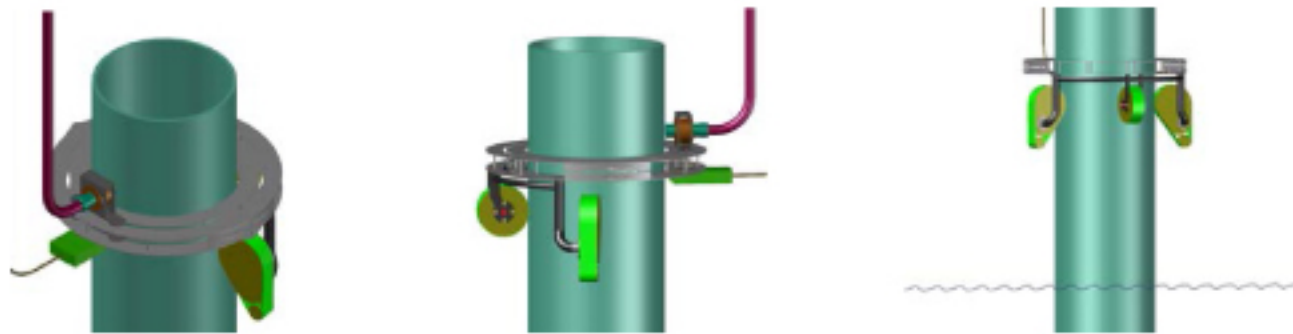

Features

- Sub sea operation
- 360 degree cleaning path
- hydroblasting up to 3000 bar

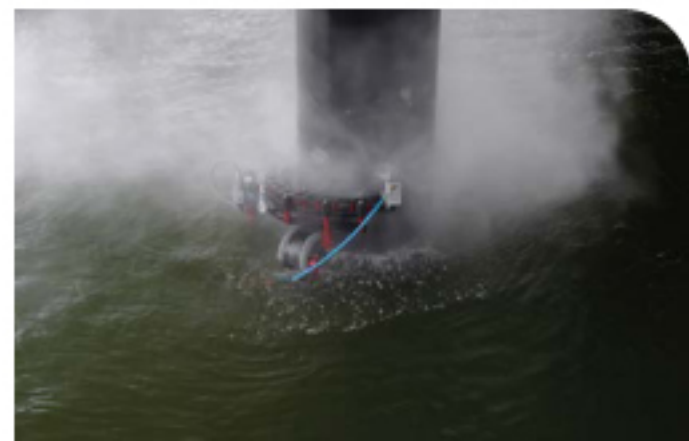

Dry/Wet Blasting

High performance open blasting

The Dry/Wet Blasting module is designed for all vertical steel open dry / wet blasting applications.

A double nozzle system mounted on the reciprocating boom ensures a very effective result. Nozzle sizes 12 - 19 mm using 10 - 15 kub compressor for each nozzle guarantees a high production. Type of blasting media used (0,2 - 1,4 size) is either aluminium oxide or garnet will do the job just fine. A nozzle distance of 50 cm and an angle of 30 degrees will give a blast patron of 2 meters wide. For dust free open blasting we do recommend to us TORBO blasting equipment.



Advantages

- Remotely controlled;
- Operator safety guaranteed;
- Very high production;
- No need for scaffolding or cherry pickers;
- The light weight construction.



Specials

Custom-made robots for your needs

Hongyuan offers you custom made state of the art solution for your surface preparation needs. We take up any challenge to position our robots any where possible. We strive for client satisfaction by designing user friendly and low maintenance machines and ensuring fast on-site support.

Operating the robot via an internet module is one of the features we can offer, two cameras and a control module plugged into any computer anywhere in the world connected to the internet will give you full control.



A plug and play containerized total solutions is one of our features.

The systems contains ;

- UHP pump with a capacity of 3000 bar @ 40ltrs/min;
- 200 meter UHP hose;
- 2 UHP hand guns ;
- 2 M3 robots & 1 M4 vacuum robot;
- 1 complete vacuum recovery system with 50 meter of vacuum hose
- Spare parts for 500 running hours.
- Protective clothing.
- Tools and workshop.

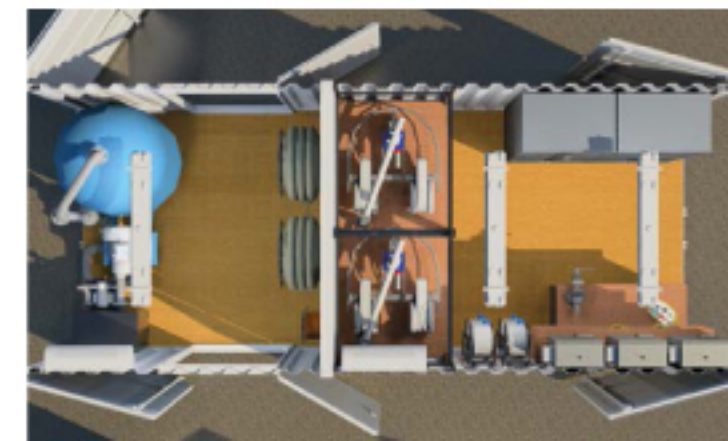

Technical specifications

The Robots

M3 Cleaning Robot

Technical specifications

Recommended pump capacity	500 bar @ 50 ltrs / min
Working width	1000 - 2500 mm
Cleaning capacity	Up to 200m ² /h
Drive system / speed	5 - 20 m/min
Weight robot	54 kg
Total weight frame and control unit	120 kg
Electrical CEE plug	220 Volt 16 Amp / 110 volt 20 Amp
Dimensions (L, W, H)	90 cm X 80 cm X 48 cm
Remote control unit	IMETM550s Zeus B withMAC receiver



M3 Ultra High Pressure

Technical specifications

Recommended pump capacity	3000 bar @ 30 ltrs / min
Working width	1600 mm
Cleaning capacity	Up to 50m ² /h
Drive system / speed	5 - 20 m/min
Weight robot	54 kg
Total weight frame and control unit	120 kg
Electrical CEE plug	220 Volt 16 Amp / 110 volt 20 Amp
Dimensions (L, W, H)	90 cm X 80 cm X 48 cm
Remote control unit	IMETM550s Zeus B withMAC receiver



M4 Vacuum

Technical specifications

Recommended pump capacity	3000 bar @ 40 ltrs / min
Working width	400 mm
Cleaning capacity	Up to 50m ² /h
Drive system / speed	5 - 20 m/min
Weight robot	72 kg
Total weight frame and control unit	135 kg
Electrical CEE plug	220 Volt 16 Amp / 110 volt 20 Amp
Dimensions (L, W, H)	120 cm X 50 cm X 45 cm
Remote control unit	IMETM550s Zeus B withMAC receiver



Wuxi Hongyuan Pump Manufacturing Co.,Ltd



No.63 Xiyi Road,
Wuxi, Jiangsu, China

Tel: +86-0510-83219970

Fax:+86-0510-83210909

E-mail:hy@chinawxhypump.com

Website:www.chinawxhypump.com